

SUPERIOR DESIGN BY NATURE



HEALTHY



QUALITY



PERFORMANCE



ENVIRONMENTALLY SENSITIVE

 **nexcem**

CONCRETE WALL FORMING SYSTEM

[WWW.NEXCEMBUILD.COM](http://WWW.NEXCEMBUILD.COM)





## IMPACT RESISTANT

Interior and exterior finishes applied over the Nexcem substrate result in a surface that is more durable and impact-resistant as compared with styrofoam ICF systems.

## HEALTHY

While the Nexcem material is inert with no VOCs or offgassing, the cement content of the Nexcem material creates an above average pH environment at the wall surface, that inhibits the growth of fungus and mold. Furthermore, the hygroscopic nature of the material moderates RH levels (60% RH maximum) and provides an inherent moisture regulator that keeps humidity low and further serves to repress any type of fungal growth.

## SOUND PROTECTION

The sound absorptive properties of our material in combination with the mass of the wall system provides an ideal combination of sound absorption and sound transmission properties. Wall Sound Transmission Coefficient (STC) ratings can range between 54 and 72 while the Nexcem material provides Noise Reduction Coefficient (NRC) ratings as high as 0.95.

## FIRE RESISTANCE

The Nexcem wall system has a four hour fire rating. The surface burning characteristics of Nexcem far surpass all other types of stay-in-place formwork. Nexcem has a flame spread and smoke spread rating of zero. Unlike foam insulation, Nexcem will not ignite, melt, sustain fire or release toxic fumes in the event of a fire.

## TERMITE RESISTANT

Unlike other ICF material, the Nexcem material provides effective resistance to termite attack. A number of testing programs have been conducted by independent agencies such as the U.S. Forestry Service. Nexcem samples were placed in termite infested areas for as long as six years without any destruction of the material.

## THERMAL PERFORMANCE

Nexcem walls provide exceptional insulation which means significant ongoing savings to building owners and increased comfort to the people who live and work in Nexcem buildings. The Nexcem wall system provides thermal performance that can be more than twice that of conventional walls.

The Wall Form units are 12" high and come in various lengths, widths and insulation values. They are dry-stacked without mortar



Nexcem is easily cut, nailed and screwed with simple carpentry tools.

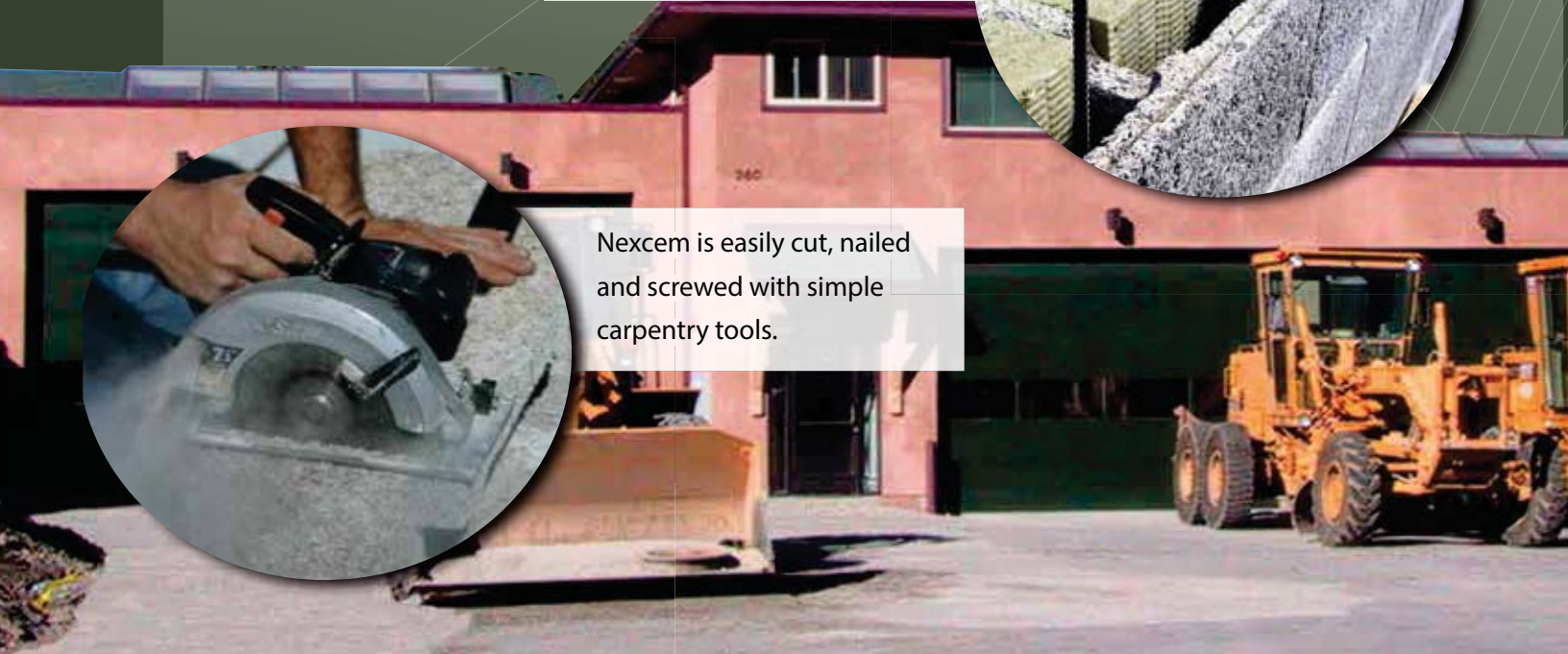



## CONCRETE WALL FORMING SYSTEM

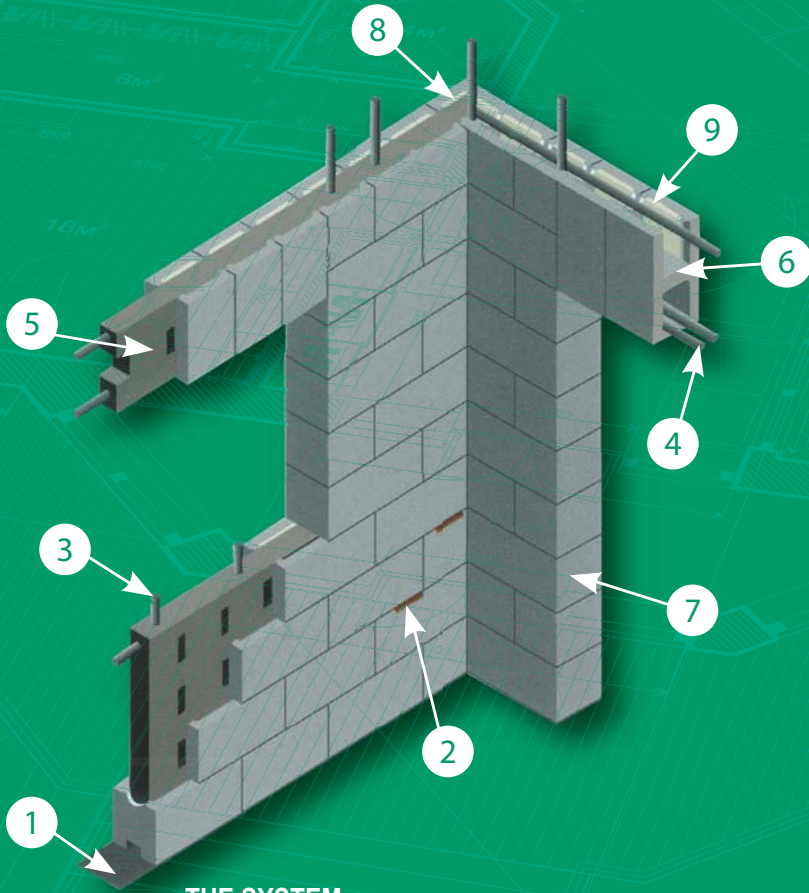

### THE SYSTEM

- 1. Optional Mortar Bed
- 2. Levelling Shims
- 3. Wall Reinforcing
- 4. Lintel Reinforcing
- 5. Concrete Fill
- 6. Lintel Form
- 7. Square End Form
- 8. Corner Form
- 9. Optional Insulation Inserts

### THE ADVANTAGE

- Lightweight
- Integral insulation
- Cut or modified with carpentry tools
- Allows winter construction
- Free-draining material allows use of high slump concrete
- Faster construction with zero voids
- Attach screws to any part of wall surface
- Insulation positioned towards the exterior for maximum thermal mass gains
- Minimal bracing required
- Proven (over 55 years, and 25-floor buildings)

### WALL FEATURES

- Fireproof
  - Over Four Hour Fire Rating
  - Zero Flame Spread (won't burn or melt)
  - Zero Fuel Contributed
  - Zero Smoke Developed
- Moisture resistant
- Rot and termite proof
- Variable R-value (R8 to R28+, see table)
- No VOCs or offgassing
- Soundproof (STC 54-72, NRC 0.75-0.95)
- Breathable (vapor permeable)
- Inhibits mold and fungal growth

### FINISHES

- Gypsum drywall can be attached directly to Nexcem at any surface location
- Ideal substrate for plaster or stucco
- Compatible with every type of exterior finish including brick or siding

Wall Form Thickness	Wall Form Length (typ)	R-Value*	Concrete Core Thickness	Concrete Fill Vol (yd <sup>3</sup> per block)
6"	24"	R-8	3"	0.018
8"	36"	R-8	5"	0.040
10"	36"	R-8 / R-14	6.5" / 5"	0.052 / 0.040
12"	24"	R-8 / R-14 / R-21	8.5" / 7" / 5.5"	0.044 / 0.035 / 0.025
14"	24"	R-8 / R-14 / R-21 / R-28	10.5" / 9" / 7.5" / 5.5"	0.055 / 0.045 / 0.036 / 0.024

Note: Basement walls and walls retaining more than 4ft of backfill typically require minimum 6.5" concrete core thickness

\*R-values quoted are steady-state, two dimensional R-values. When comparing in-service performance, the R-14 Nexcem wall system have been demonstrated to perform better than an R-20 conventionally framed 2x6 wall. The actual performance of any wall system will depend on a number of project specific items, including window area and type, climatic data, building orientation, site condition, etc.



# THE SYSTEM

Nexcem is a modular, insulated, stay-in-place, concrete forming system. Units are made from recycled waste wood (100% natural clean lumber) that is bonded with standard Portland Cement. The wall forms are simply dry-stacked and filled with concrete and reinforcing steel. Our thermal Wall Forms incorporate mineral-fiber (rockwool) insulation that is non-combustible, moisture resistant and positioned toward the exterior of the wall, resulting in additional energy efficiency that is not possible with other insulating concrete forms.

Builders choose Nexcem because of the ease with which walls can be constructed. The Nexcem material is light-weight, easily cut, nailed and screwed with simple carpentry tools. Nexcem's insulating properties allow easy winter construction without any additional heating. The unique free-draining Nexcem material allows the use of high-slump concrete in the field making for easier and faster concrete pouring and ensuring a solid wall without any compromise in strength.

Interior and exterior finishes are applied directly to the Nexcem material, eliminating subsequent steps in the construction process. Drywall can be attached anywhere on the Wall Form surface, while the open-textured nature of hardened Nexcem makes it an ideal substrate for plasters and stucco.



Pour concrete faster and easier without worries about blowouts, wall alignment or voids.



Accommodates electrical wires and services, either on or within the Nexcem surface



CONCRETE WALL FORMING SYSTEM

WWW.NEXCEMBUILD.COM



# THE REASON

When designing and building a structure, whether it's a high-rise hotel or your ultimate dream home, the decisions you make today will have implications on the comfort, quality and performance that are provided to your occupants. Incorporating materials like Nexcem that are superior to conventional construction, while having minimal impact on the environment around us, will guarantee that your building and surroundings will endure for generations to come.

When designers and builders make cost-effective and technically superior decisions in a manner that is environmentally responsible, they are providing the best design solution for both the owner and the environment. They are acting in the best interests of their profession and their community. The choice of using Nexcem reflects this commitment to your environment while building value and quality for your client.

The Nexcem Wall Form was first manufactured in 1946 to help rebuild post-war Europe at a time when resources were scarce. Our product line has since expanded to include roof panels, floor forms, noise barriers, retaining walls, bridge panels and even wine storage cabinets. With this proven history of versatility, performance and durability, your reputation can safely stand on our reputation.



The hygroscopic nature of Nexcem moderates humidity levels, inhibits mold growth and contributes significantly to a healthy living space.



Interior finishes such as plasters and drywall are easily applied directly to the Nexcem material. Exterior finishes are also applied over the Nexcem. (weather/air barrier is required)





SUPERIOR DESIGN BY NATURE



### TIME TESTED DURABILITY

Nexcem products have been installed around the world for over sixty years. They have withstood hot and humid climates, freezing and thawing, termites, fungus and fire without loss of performance or surface damage.

Our Nexcem team provides technical support from the concept stage through installation. Assistance with installation techniques is provided as well as overseeing component assembly to ensure optimum efficiency in product performance.

We recommend construction techniques, assemblies and other complementary products that meet most budget and performance specifications. Our proven record of innovation, outstanding product performance and unsurpassed service has earned us an international reputation as a company with vision and integrity.

Nexcem Inc.

4145 North Service Rd, 2nd Floor  
Burlington, Ontario, Canada L7L 6A3

T: 647-494-0088

E: [info@nexcembuild.com](mailto:info@nexcembuild.com)

W: [www.nexcembuild.com](http://www.nexcembuild.com)

Eco-Building Products, Inc.

231-399-0700

[Sales@Eco-BuildingProducts.com](mailto:Sales@Eco-BuildingProducts.com)

[www.Eco-BuildingProducts.com](http://www.Eco-BuildingProducts.com)

